

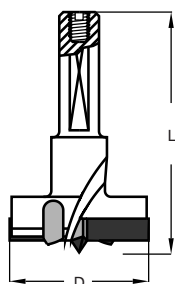

MPK

Boring Bits

Combi system—Carbide tipped with centering point, 2 straight cutting edges and 2 nicking teeth. With adjustable set-screw in shank. Fits 10mm combi chucks Right hand and left hand rotation.



Tool No.	D mm	L mm
MPK1507	15	57.5
MPK1607	16	57.5
MPK1807	18	57.5
MPK2007	20	57.5
MPK2207	22	57.5
MPK2507	25	57.5
MPK2607	26	57.5
MPK3007	30	57.5
MPK3507	35	57.5
MPK3807	38	57.5
MPK4007	40	57.5
MPK1517	15	70
MPK2017	20	70
MPK2517	25	70
MPK3017	30	70
MPK3517	35	70
MPK2527	25	77
MPK3027	30	77
MPK3527	35	77

Adjustable screw No. M6 x 11

While ordering left hand rotation tools add the suffix-L (for example: MPK3507L)

MPA

Adjustable Boring Bits

Carbide tipped with centering point, 2 scorers, one fixed and one adjustable.

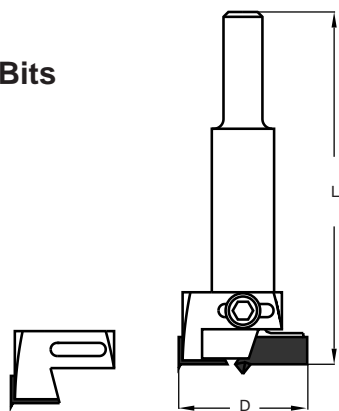

10mm shank

Tool No.	D mm	L mm	Replacement Knife
MPA3007	30-60	90	MPA3000; MPA4500

1/2" shank

MPA6008	60-80	100	MPA6000
---------	-------	-----	---------

Knife MPA3000 for Dia. 30-45mm
Knife MPA4500 for Dia. 45-60mm

MP

Boring Bits

For blind holes. Carbide tipped with centering point, 2 straight cutting edges and 2 nicking teeth.

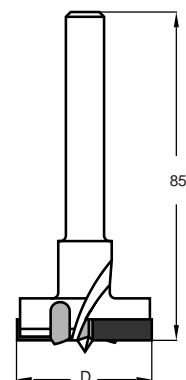

10mm shank

Tool No.	D mm
MP15007	15
MP20007	20
MP22007	22
MP25007	25
MP26007	26
MP30007	30
MP35007	35
MP38007	38
MP40007	40
MP45007	45
MP50007	50

Other sizes available on request

HMP

Boring Bits

For blind holes
DIY performance

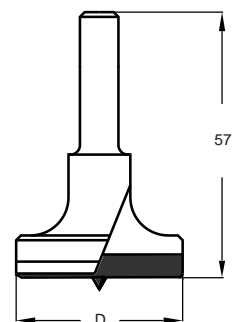

8mm shank

Tool No.	D mm
HMP2005	20
HMP2505	25
HMP2605	26
HMP3005	30
HMP3505	35

HMPS

Boring Bits 5 Pcs Set

Set No. HMPS055

Boring Bits in a wooden box.





AC0

Countersinks

Carbide tipped
For wood screws sizes #2 - #14

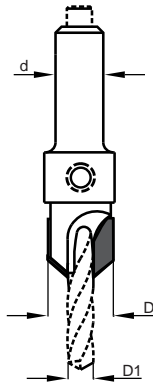

Tool No.	D1		D		d	
	mm	inch	mm	inch	mm	inch
AC02405	2.4	3/32	8.0	5/16	8	5/16
AC03205	3.2	1/8	9.5	3/8	8	5/16
AC03215	3.2	1/8	8.0	5/16	8	5/16
AC03285	3.2	1/8	12.7	1/2	8	5/16
AC03605	3.6	9/64	10.0	.394	8	5/16
AC04005	4.0	5/32	10.0	.394	8	5/16
AC04405	4.4	11/64	11.1	7/16	8	5/16
AC04807	4.8	3/16	11.1	7/16	9.5	3/8
AC04817	4.8	3/16	12.7	1/2	9.5	3/8
AC05607	5.6	7/32	12.0	.472	9.5	3/8
AC05617	5.6	7/32	12.7	1/2	9.5	3/8
AC06007	6.0	15/64	12.7	1/2	9.5	3/8
AC06307	6.3	1/4	12.7	1/2	10	.394

Available with regular or slow spiral drills

AC2

Countersinks

Carbide tipped
For wood screws sizes #14 - #24

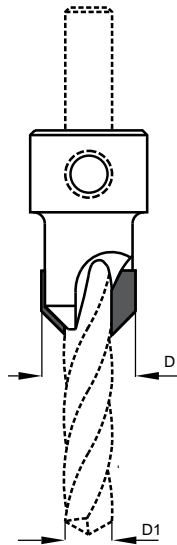

Tool No.	D1		D	
	mm	inch	mm	inch
AC20540	5.4	.212	16	5/8
AC26320	6.3	1/4	16	5/8
AC27020	7.1	9/32	16	5/8
AC20731	7.3	.287	18	.709
AC28020	8.0	5/16	16	5/8
AC28030	8.0	5/16	19	3/4
AC20900	9.0	.354	18	.709
AC29530	9.5	3/8	19	3/4

Available with regular or slow spiral drills

AC4

Counterbores

Flat bottom, Carbide tipped
For wood screws sizes #2 - #14

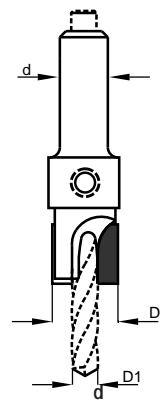
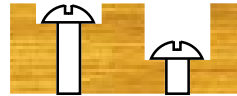

Tool No.	D1		D		mm	inch
	mm	inch	mm	inch		
AC43205	3.2	1/8	9.5	3/8	8.0	5/16
AC44005	4.0	5/32	10.0	.394	8.0	5/16
AC44405	4.4	11/64	10.0	.394	8.0	5/16
AC44817	4.8	3/16	12.7	1/2	9.5	3/8
AC45617	5.6	7/32	12.7	1/2	9.5	3/8
AC46017	6.0	15/64	12.7	1/2	9.5	3/8
AC46317	6.3	1/4	12.7	1/2	9.5	3/8

Available with regular or slow spiral drills

AC4

Counterbores

Flat bottom, Carbide tipped
For wood screws sizes #14 - #24

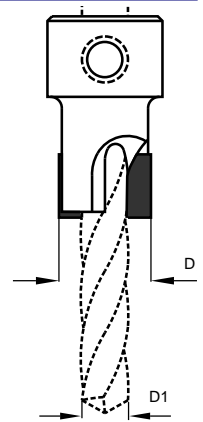
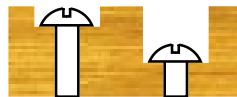

Tool No.	D1		D	
	mm	inch	mm	inch
AC46320	6.3	1/4	16.0	5/8
AC47020	7.1	9/32	16.0	5/8
AC48020	8.0	5/16	16.0	5/8
AC48030	8.0	5/16	19.0	3/4
AC49530	9.5	3/8	19.0	3/4

Available with regular or slow spiral drills

AC3

Countersinks

For dowel drills
Carbide tipped

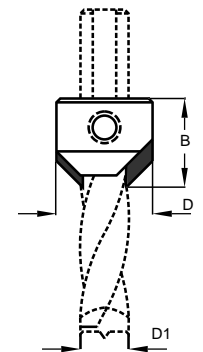

Tool No.	Rotation	D1	D	B
		mm	mm	mm
AC3050R	right	5.0	16	18
AC3050L	left	5.0	16	18
AC3080R	right	8.0	18	18
AC3080L	left	8.0	18	18
AC3100R	right	10.0	20	18
AC3100L	left	10.0	20	18
• AC3510R	right	5.0 - 10.0	20	19
• AC3510L	left	5.0 - 10.0	20	19

• Suitable for drills from 5 to 10mm Dia.

PL

Countersink & Plug Cutter Set

For decorative concealing of screw heads
Drilling & Countersinking with a single tool.
Concealing of screwheads with plugs which perfectly fit with countersink.

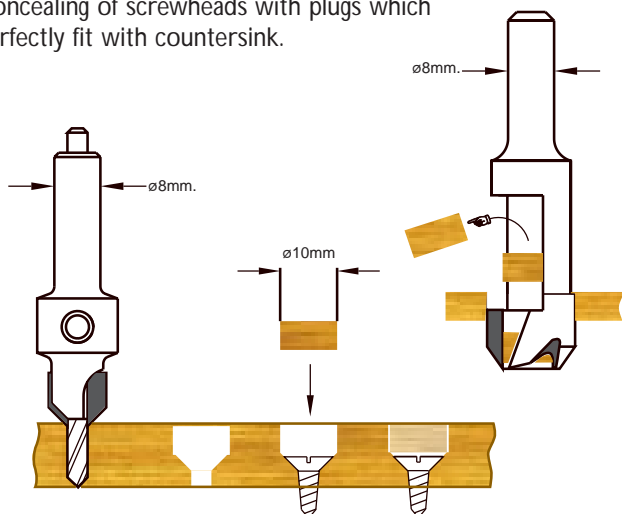

The range includes countersink bits with different drill bits and 10mm plug cutter, which fits with all countersinks.



Set No.	Description
---------	-------------

Metric sizes

PL10305	2 pcs.- plug cutter & Countersink with 3mm drill
PL10355	2 pcs.- plug cutter & Countersink with 3.5mm drill
PL10405	2 pcs.- plug cutter & Countersink with 4mm drill
PL10505	2 pcs.- plug cutter & Countersink with 5mm drill
PL40005	5 pcs.- plug cutter & 4 above mentioned Countersinks

Inch sizes

PL10325	2 pcs.- plug cutter & Countersink with 1/8" drill
PL10365	2 pcs.- plug cutter & Countersink with 9/64" drill
PL10405	2 pcs.- plug cutter & Countersink with 5/32" drill
PL10445	2 pcs.- plug cutter & Countersink with 11/64" drill
PL41005	5 pcs.- plug cutter & 4 above mentioned Countersinks

Replacement Plug cutter: MN10005

Countersinks :

Metric sizes		Inch sizes	
Tool No.	Drill Dia.	Tool No.	Drill Dia.
AC10305	3mm	AC10325	1/8"
AC10355	3.5mm	AC10365	9/64"
AC10405	4mm	AC10405	5/32"
AC10505	5mm	AC10445	11/64"

All countersinks are carbide-tipped. The plug cutter and drill bits are high-speed steel.

MN

Plug Cutters HS Steel

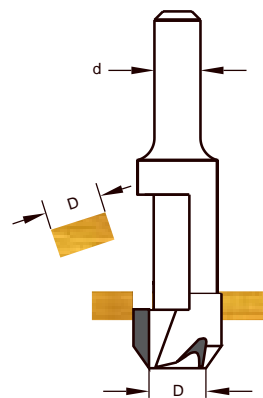

Tool No.	D		d	
	mm	inch	mm	inch
MN10005	10.0	.394	8	5/16
MN12705	12.7	1/2	8	5/16
MN16007	16.0	5/8	10	.394
MN19007	19.0	3/4	10	.394

ACD

3 steps Drill Bits

For Connecting Screws.

2 steps steel made countersink,
surface treated for very high hardness.
HSS Slow Spiral drill

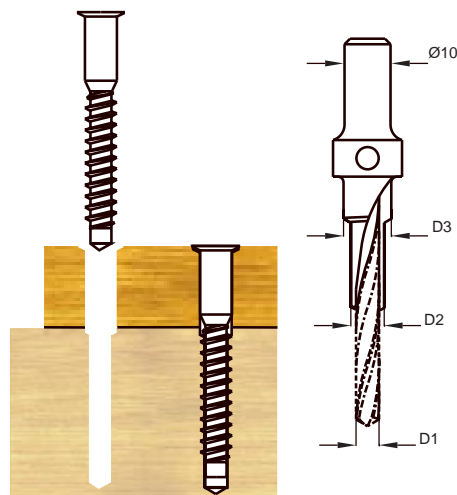

Tool No.	D1	D2	D3
	mm	mm	mm
ACD0507	3.5	5	7
ACD0707	5.0	7	10

Replaceable slow spiral drills:

DRS0350 - 3.5mm Dia.
DRS0500 - 5.0mm Dia.